

1999-2006 Chevy / GMC 1500 2WD 7" Lift



**SHIPPING
MAY 21, 2007**

2WD Pickup with Coil Spring Front Suspension • 7" Replacement Knuckle System (extended cab only)

New coil springs, replacement steering knuckles, lower control arm crossmembers and our unique suspension travel control system form the heart of this true performance system. 7" of front lift (5" rear) allows plenty of clearance for 35" rubber in all on or off-road situations.

Proper suspension travel control is crucial yet often overlooked. Superlift replaces the factory compression travel-stops with new units designed specifically for the 1/2-ton GM. These new stops feature a higher compression rate to offset the increased load generated by wider / heavier tires and wheels, making them better suited for performance driving. We include shims that allow you to precisely "tune" your vehicle's ride and handling characteristics. Increase stop-to-control arm clearance for a more compliant ride; reduce stop-clearance for a firmer ride and more control. This adjustable stop-clearance feature is a Superlift exclusive. Superlift also includes new extension travel-stop brackets to ensure proper engagement and control.

Rear lift is via 5" rear blocks which work well with the factory rear springs, considered a good design worth keeping. The system includes front / rear Superlift Superide shocks.

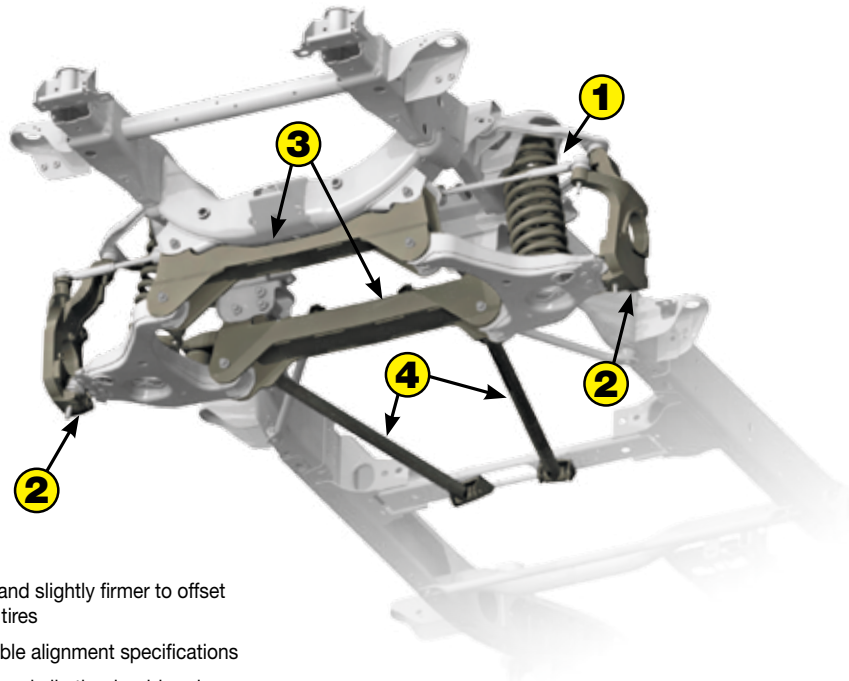

- ① New coils are pre-set to minimize settling, and slightly firmer to offset additional leverage / load generated by wider tires
- ② Replacement knuckles yield the best possible alignment specifications
- ③ High clearance, one-piece crossmembers, and all other load-bearing bracketry are laser cut from .25" thick plate steel
- ④ Kicker braces further increase overall rigidity



Installation Info.



Install Time	Difficulty Rating	Cutting or Welding
5-6 hrs.	4	Cutting

Tire and Wheel Information

Max. Tire Diameter	Fender Trimming	Max. Tire Width	Min. Wheel Diameter	Wheel Width	Minimum Backspacing	Maximum Backspacing	Stock Wheels
35"	No	12.5"	16"	8"	4.625"	5.5"	Spare Only





CHEVY / GMC - SUSPENSION SYSTEMS			
PICKUP - SILVERADO / SIERRA 1500 2WD EXT. CAB ONLY			
1999-06			
7" FRONT / 5" REAR			
LIFT HEIGHT & METHOD	MASTER PACK	(QTY) & PART NUMBER - BASE KIT COMPONENTS	
REP. STEERING KNUCKLES COIL SPRINGS & DROP BRKTS REAR 5" BLOCKS	K870 SUPERIDE	(1) 338 FRONT COIL SPRINGS (1) 3380 FRT. KIT BOX W/ SUPERIDE SHOCKS (1) 3381 FRONT KIT BOX (1) 3382 REAR KIT BOX	
SEE OPTIONS BELOW			
OPTIONS		OPTIONS	OPTIONS
SPEED SENSOR CALIBRATOR			
33003 TRUSPEED SPEED SENSOR CALIBRATOR			
34000 ABS SIGNAL CORRECTOR (A)			

NOTES:
36
138

NOTES:

- (A) 34000 Needed only if vehicle has 4.56 or lower (numerically higher) axle gear ratio.
- 36 Minor cutting and / or welding required.
- 138 New wheel with backspacing of maximum 5.5" and minimum 4.625" is required for installation. Factory spare can be used as a temporary spare in emergency situations.

1999-2006 Chevy / GMC Pickup 1500 2WD Ext. Cab ONLY			
Part #	Jobber	UPC	Box Deminsions
K870	1739.49	804260047641	63.5x40x20.5
338	253.33	804260048181	23x11.75x5.75
3380	1002.47	804260048198	33x15x6.25
3381	387.60	804260048204	33x15x6.25
3382	96.10	804260048211	20x6.25x6.25
33003	247.85	804260018078	6x4x3
34000	109.22	804260026967	6x4x3