



SUPERLIFT SUSPENSION SYSTEMS

300 Huey Lenard Loop Rd.
West Monroe, Louisiana 71292
Phone: (318) 397-3000
Sales / Tech: 1-800-551-4955
FAX: (318) 397-3040
www.superlift.com

**Superlift® Level-It System for
2007 and Newer General Motors 1500 Series Pickups and SUVs, 2WD and 4WD**

INSTALLATION INSTRUCTIONS

INTRODUCTION

Installation requires a professional mechanic. Prior to beginning, inspect the vehicles steering, driveline, and brake systems, paying close attention to the control arms and bushings, anti-sway bars and bushings, steering linkage, ball joints and wheel bearings. Also check the steering sector-to-frame and all suspension-to-frame attaching points for stress cracks. The overall vehicle must be in excellent working condition; repair or replace all worn parts.

Read instructions several times before starting. Be sure you have all needed parts and know where they install. Read each step completely as you go.

NOTES:

- **Prior to beginning the installation, check all parts and hardware in the box with the parts list below. If you find a packaging error, contact Superlift® directly. Do not contact the dealer where the system was originally purchased. You will need the control number from each box when calling; this number is located at the bottom of the part number label and to the right of the bar code.**
- Front end realignment is necessary.
- A foot-pound torque reading is given in parenthesis () after each appropriate fastener.
- Do not install any additional components or modify this system to gain additional suspension height.
- Prior to attaching components, be sure all mating surfaces are free of grit, grease, undercoating, etc.
- Speedometer recalibration will be recommended if a taller tire is used.
- A factory service manual should be on hand for reference.
- Use the check-off box "☐" found at each step to help you keep your place. Two "☐☐" denotes that one check-off box is for the driver side and one is for the passenger side.

PARTS LIST ... The part number is stamped into each part or printed on an adhesive label. Identify each part and place the appropriate mounting hardware with it.

PART NO	DESCRIPTION (Qty.- if more than one)	NEW ATTACHING HARDWARE (Qty.- if more than one)
66-01-30100	(2) strut spacer ring	(6) 10mm flange nut
00461.....	decals, "Warning To Driver"	
00421.....	decals, Superlift® die-cut	

INSTALLATION PROCEDURE

NOTE: Save all factory components and hardware for reuse.

1) PREPARE VEHICLE... Place vehicle in neutral. Raise front of vehicle with a jack and secure a jack stand beneath each frame rail, behind the lower control arms. Ease the frame down onto the stands, place transmission in low gear or “park”, and chock rear tires. Remove front tires.

2) STRUT REMOVAL... Steps 2 and 3 are performed one side at a time.

IMPORTANT: Eccentric cam bolts connect the upper control arm-to-frame, and are also used for front end alignment. In later steps the eccentrics must be restored to their pre-lift position for alignment to be “in the ball park” prior to final alignment. Prior to loosening, scribe a line on each eccentric washer, and the flanges they contact, for later reference.

Loosen, do not remove, all four control arm-to-frame bolts (both upper and lower control arms). Rotate the uppercam bolts so the upper control arm is as far to the outside of the vehicle as possible. This will aid in removing the strut.

Mark the location of each strut assembly (driver and passenger side), as well as the outermost stud of each strut, for reference during reassembly.

Remove the two bolts securing the strut-to-lower control arm, followed by the three nuts securing the strut-to-frame. Remove the strut assembly.

3) STRUT SPACER INSTALLATION...

[SEE DIAGRAM] Position spacer #66-01-30100 as shown.

Secure upper end of the strut assembly-to-frame using the supplied 10mm flange nuts. Do not tighten at this time.

Attach lower end of the strut assembly-to-control arm using the factory hardware. Tighten both upper and lower ends of strut assembly (37).

Perform steps 2 and 3 on opposite side.

4) TIRES / WHEELS... [SEE DIAGRAM - TORQUE SEQUENCE] Tighten lug nuts (140) in the sequence shown.

WARNING: When the tires / wheels are installed, always check for and remove any corrosion,

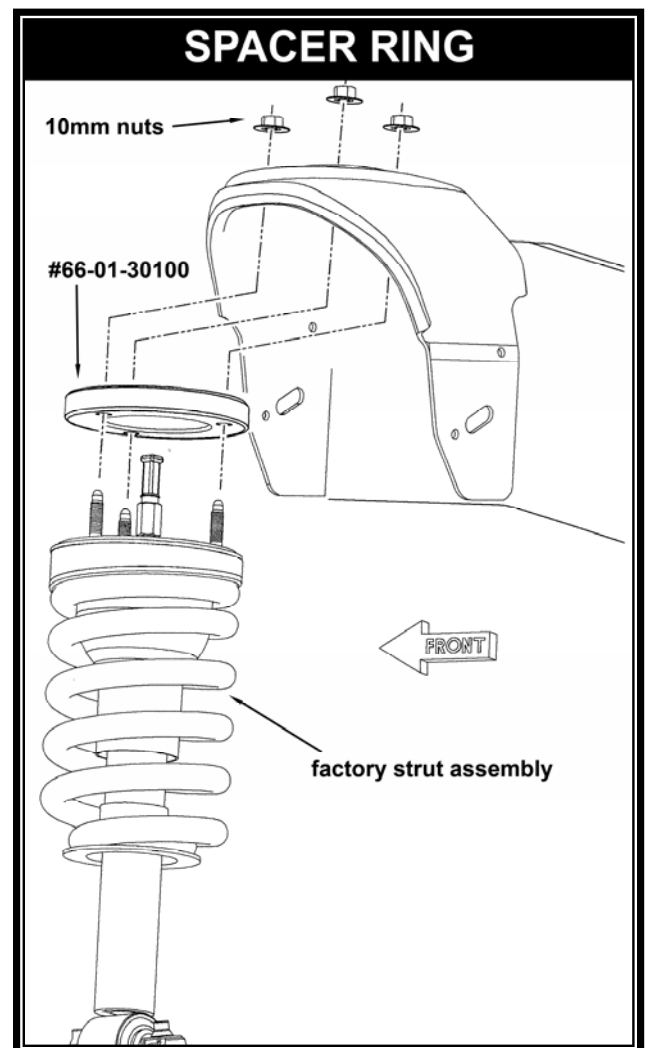

dirt, or foreign material on the wheel mounting surface, or anything that contacts the wheel mounting surface (hub, rotor, etc.). Installing wheels without the proper metal-to-metal contact at the wheel mounting surfaces can cause the lug nuts to loosen and the wheel to come off while the vehicle is in motion.

WARNING: Retighten lug nuts at 500 miles after any wheel change, or anytime the lug nuts are loosened. Failure to do so could cause wheels to come off while vehicle is in motion.

5) INITIAL CLEARANCE CHECK... With the vehicles frame rails still on jack stands, and the suspension “hanging” at full extension travel, cycle steering lock-to-lock and check all components for proper operation and clearances. Pay special attention to the clearance between the tires / wheels and brake hoses, wiring, etc.

6) CONTROL ARMS...

Lower vehicle to the floor. The suspension is now supporting vehicle weight. Prior to tightening the upper control arm eccentric cam bolts, align the scribe marks made in step 2 (140).

Tighten lower control arm bolts (129).

7) FINAL CLEARANCE and TORQUE CHECK... With vehicle on floor, cycle steering lock-to-lock and inspect the tires / wheels, and the steering, suspension, and brake systems for proper operation, tightness, and adequate clearance.

8) HEADLIGHTS... Readjust headlights to proper setting.

9) SUPERLIFT® WARNING DECAL... Install the WARNING TO DRIVER decal on the inside of the windshield, or on the dash, within driver’s view. Review the “IMPORTANT PRODUCT USE AND SAFETY INFORMATION / WARNINGS” text found at the end of this instruction sheet.

10) ALIGNMENT... Realign vehicle to factory specifications.

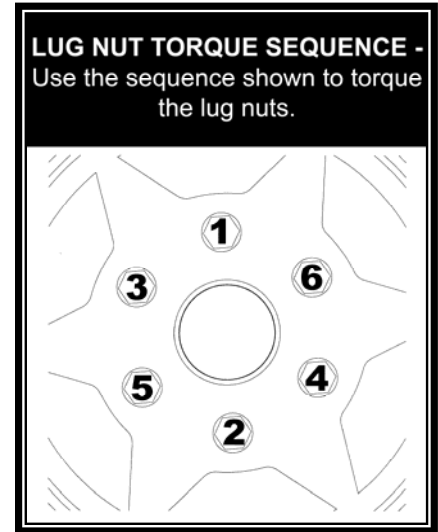

Limited Lifetime Warranty / Warnings

Your Superlift® product is covered by the Limited Warranty explained below that gives you specific legal rights. This limited warranty is the only warranty Superlift® makes in connection with your product purchase. Superlift® neither assumes nor authorizes any retailer or other person or entity to assume for it any other obligation or liability in connection with this product or limited warranty.

What is covered? Subject to the terms below, Superlift® will repair or replace its products found defective in materials or workmanship for so long as the original purchaser owns the vehicle on which the product was originally installed. Your warrantor is LKI Enterprises, Inc. d/b/a Superlift® Suspension Systems (“Superlift®”).

What is not covered? Your Superlift® Limited Warranty does not cover products, parts or vehicles Superlift® determines to have been damaged by or subjected to:

- Alteration, modification or failure to maintain.
- Normal wear and tear (bushings, tie-rod ends, etc.). Scratches or defects in product finishes (powder coating, plating, etc.),
- Damage to or resulting from vehicle's electronic stability system, related components or other vehicle systems.
- Racing or other vehicle competitions or contests. Accidents, impact by rocks, trees, obstacles or other aspects of the environment.
- Theft, vandalism or other intentional damage.

Remedy Limited to Repair / Replacement. The exclusive remedy provided hereunder shall, upon Superlift's inspection and at Superlift's option, be either repair or replacement of product or parts covered under this Limited Warranty. Customers requesting warranty consideration should contact Superlift® by phone (1-800-551-4955) to obtain a Returned Goods Authorization number. All removal, shipping and installation costs are customer's responsibility.

If a replacement part is needed before the Superlift® part in question can be returned, you must first purchase the replacement part. Then, if the part in question is deemed warrantable, you will be credited / refunded.

Other Limitations - Exclusion of Damages - Your Rights Under State Law

- Neither Superlift® nor your independent Superlift® dealer are responsible for any time loss, rental costs, or for any incidental, consequential or other damages you may have.
- This Limited Warranty gives you specific rights. You may also have other rights that vary from state to state. For example, while all implied warranties are disclaimed herein, any implied warranty required by law is limited to the terms of our Limited Lifetime Warranty as described above. Some states do not allow limitations of how long an implied warranty lasts and / or do not allow the exclusion or limitation of incidental or consequential damages, so the limitations and exclusions herein may not apply to you.

Important Product Use and Safety Information / Warnings

As a general rule, the taller a vehicle is, the easier it will roll over. Offset, as much as possible, what is lost in rollover resistance by increasing tire track width. In other words, go "wide" as you go "tall". Many sportsmen remove their mud tires after hunting season and install ones more appropriate for street driving; always use as wide a tire and wheel combination as feasible to enhance vehicle stability. We strongly recommend, because of rollover possibility, that the vehicle be equipped with a functional roll bar and cage system. Seat belts and shoulder harnesses should be worn at all times. Avoid situations where a side rollover may occur.

Generally, braking performance and capabilities are decreased when significantly larger / heavier tires and wheels are used. Take this into consideration while driving. Also, changing axle gear ratios or using tires that are taller or shorter than factory height will cause an erroneous speedometer reading. On vehicles equipped with an electronic speedometer, the speed signal impacts other important functions as well. Speedometer recalibration for both mechanical and electronic types is highly recommended.

Do not add, alter, or fabricate any factory or aftermarket parts to increase vehicle height over the intended height of the Superlift® product purchased. Mixing component brands is not recommended.